

GSM Antenna

Part Number: VTGSMA-70

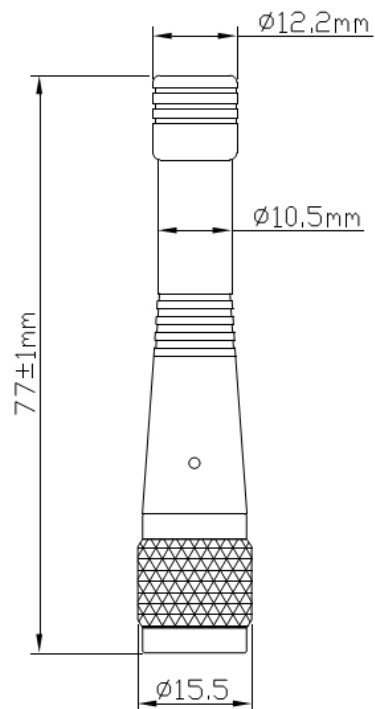

1 Dimension (Unit: mm)



2. Electrical Characteristics

2.1 Dielectric Antenna

V.TORCH

Form 1

No	Item	Specifications
1	Frequency (MHz)	868-928MHZ
2	V.S.W.R (5m)	≤1.2.0
3	Gain (Zenith)	2.5db
4	Impedance	50 Ω
5	Polarization	Vertical
6	Other Protection	IP67 UV Protected
7	Max Power	50W
8	Temp	-30°~80°

3.2 Mechanical

Form 2

No.	Item	Specification
1	Connector	TNC RP PLUG
2	Cable	---
3	Plastic Housing	Black
4	Height	77mm
5	Max diameter	15.5mm
6	Min diameter	10.5mm

V.TORCH

CH1 A/R SWR MKR 1: 1.5003 U
REF 1.000 U 1.000U/ 865 000 000.HZ

