

GPS+GSM Combined Antenna

Part Number: VTGPSM-8

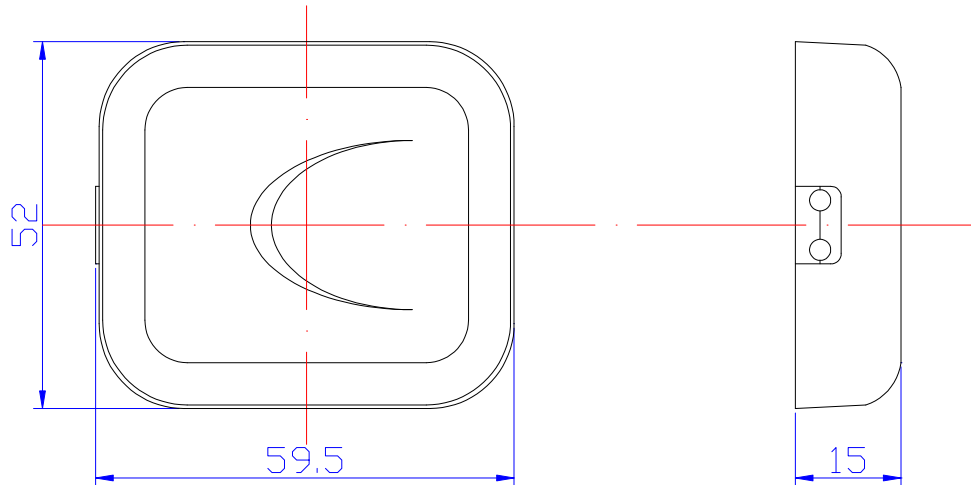

1 Dimension (Unit: mm)



2 Electrical Characteristics

3.1 Dielectric Antenna

Form 1

No.	Item	Specifications	Post Environmental Tolerance
1	Center Frequency	1575.42 MHz	±3 MHz

V.TORCH

2	Band Width	±5 MHz	±1 MHz
3	V.S.W.R (in BW)	1.5 : 1	—
4	Gain (Zenith)	3 dB	±0.5 dB
5	Polarization	RHCP	—
6	Impedance	50 Ω	—

3.2 LNA/Filter

Form 2

No.	Item	Specifications	Post Environmental Tolerance
1	LNA Gain	28±2 dB	±2.5 dB
2	Noise Figure	1.5 dB	—
3	Filter Out Band Attenuation	12dB Min f0+50MHz 16dB Min f0-50MHz	±1.0 dB
4	DC Voltage	2.2~5V	
5	DC Current	5~15mA	

3.3 GSM Antenna

Form 3

No.	Item	Specifications
1	Frequency	824~960 MHz/1710~1990 MHz
2	V.S.W.R (5m)	≤2.0 : 1
3	Gain (Zenith)	2 dBi
4	Impedance	50 Ω

3.4 Mechanical

Form 4

No.	Item	Specification
1	Cable	RG174 3m/5m or others
2	Connector	SMA/SMB/MCX or others
3	Plastic Housing	Black
4	Mounting	Magnet/Adhesive

4 Reliability

Condition: Temperature: 40±5°C

Load: DC=5V±0.5 V

Quantity: 2000pcs

Sustained Time: 480h

5 Environmental Specifications

Post Environmental Tolerance (Refer to the form 1~2)

V.TORCH

Condition: Temperature range $25\pm 3^{\circ}\text{C}$

Relative Humidity range 55~75%RH

Operating Temperature range $-40^{\circ}\text{C}\sim+85^{\circ}\text{C}$

Storage Temperature range $-40^{\circ}\text{C}\sim+100^{\circ}\text{C}$

5.1 Moisture Proof

The device should satisfy the electrical characteristics specified in form 1~2 after exposed to the temperature $40\pm 2^{\circ}\text{C}$ and the relative humidity 90~95% RH for 96 hours and 1~2 hours recovery time under normal condition.

5.2 Vibration Resist

The device should satisfy the electrical characteristics specified in form 1~2 after applied to the vibration of 10 to 55Hz with amplitude of 1.5mm for 2 hours each in X , Y and Z directions.

5.3 Drop Shock

The device should satisfy the electrical characteristics specified in form 1~2 after dropping onto the hard wooden board from the height of 30cm for 3 times each facet of the 3 dimensions of the device.

5.4 High Temperature Endurance

The device should satisfy the electrical characteristics specified in form 1~2 after exposed to temperature $80\pm 5^{\circ}\text{C}$ for 24 ± 2 hours and 1~2 hours recovery time under normal temperature.

5.5 Low Temperature Endurance

The device should also satisfy the electrical characteristics specified in form 1~2 after exposed to the temperature $-40^{\circ}\text{C}\pm 5^{\circ}\text{C}$ for 24 ± 2 hours and to 2 hours recovery time under normal temperature.

5.6 Temperature Cycle Test

The device should also satisfy the electrical characteristics specified in form 1~2 after exposed to the low temperature -25°C and high temperature $+85^{\circ}\text{C}$ for 30 ± 2 min each by 5 cycles and 1 to 2 hours recovery time under normal temperature.

6 Weatherproof

Put the antennas in 1m deep water for 12h, and find 100% waterproof.