

## GPS+GSM Combined Antenna

Part Number: VTGPSM-4

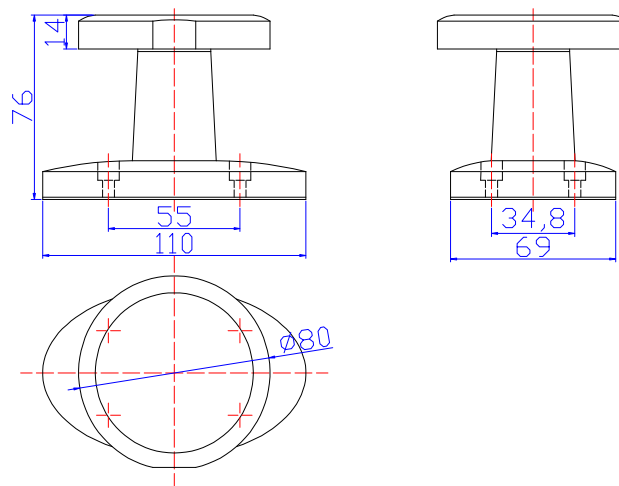

### 1 Dimension (Unit: mm)



### 2 Electrical Characteristics

#### 3.1 Dielectric Antenna

Form 1

No.	Item	Specifications	Post Environmental Tolerance
1	Center Frequency (MHz)	1575.42 MHz	±3 MHz
2	Band Width (MHz)	±5 MHz	±1 MHz
3	V.S.W.R (in BW)	1.5 : 1	—
4	Gain (Zenith)	3 dB	±0.5 dB
5	Polarization	RHCP	—
6	Impedance	50 Ω	—

#### 3.2 GSM Antenna

Form 2

No.	Item	Specifications	Post Environmental Tolerance

# V.TORCH

1	Center Frequency	824MHz~894MHz/1710MHz~1990MHz 880MHz~960MHz/1710MHz~1990MHz	±3 MHz
2	V.S.W.R (5m)	2.0 : 1	—
3	Gain (Zenith)	2dB±1dB@900MHz or 1dB±1dB@1800MHz	±0.5dB
4	Impedance	50Ω	—

### 3.3 LNA/Filter

Form 3

No.	Item	Specifications	Post Environmental Tolerance
1	LNA Gain	28±3 dB	±2.5 dB
2	Noise Figure	1.5 dB	—
3	Filter Out Band Attenuation	14dB Min f0+50MHz 18dB Min f0-50MHz 30dB Min f0+100MHz 42dB Min f0-100MHz	±1.0 dB
4	DC Voltage	3~5V	
5	DC Current	8~15mA	

### 3.4 Mechanical

Form 4

No.	Item	Specification
1	Cable	RG174 3m/5m or others
2	Connector	SMA/SMB/MCX or others
3	Plastic Housing	Black or White
4	Mounting	Screw

### 4 Reliability

Condition: Temperature: 40±5℃

Load: DC=5V±0.5 V

Quantity: 2000pcs

Sustained Time: 480h

### 5 Environmental Specifications

Condition:

Post Environmental Tolerance (Refer to the form 1~3 )

Temperature range 25±3℃

Relative Humidity range 55~75%RH

Operating Temperature range -40℃~+85℃

Storage Temperature range -40℃~+100℃

#### 5.1 Moisture Proof

The device should satisfy the electrical characteristics specified in form 1~3 after exposed to the temperature 40±2℃ and the relative humidity 90~95% RH for 96 hours and 1~2 hours recovery time under normal condition.

#### 5.2 Vibration Resist

The device should satisfy the electrical characteristics specified in form 1~3 after applied to the vibration of 10 to 55Hz with amplitude of 1.5mm for 2 hours each in X , Y and Z directions.

#### 5.3 Drop Shock

# V.TORCH

The device should satisfy the electrical characteristics specified in form 1~3 after dropping onto the hard wooden board from the height of 30cm for 3 times each facet of the 3 dimensions of the device.

## 5.4 High Temperature Endurance

The device should satisfy the electrical characteristics specified in form 1~3 after exposed to temperature  $80\pm 5^{\circ}\text{C}$  for  $24\pm 2$  hours and 1~2 hours recovery time under normal temperature.

## 5.5 Low Temperature Endurance

The device should also satisfy the electrical characteristics specified in form 1~3 after exposed to the temperature  $-40^{\circ}\text{C}\pm 5^{\circ}\text{C}$  for  $24\pm 2$  hours and to 2 hours recovery time under normal temperature.

## 5.6 Temperature Cycle Test

The device should also satisfy the electrical characteristics specified in form 1~3 after exposed to the low temperature  $-25^{\circ}\text{C}$  and high temperature  $+85^{\circ}\text{C}$  for  $30\pm 2$  min each by 5 cycles and 1 to 2 hours recovery time under normal temperature.

## 6 Weatherproof

Put the antennas in 1m deep water for 12h, and find 100% waterproof.