

GPS&GLONASS+GSM Combination Antenna **VTGLMA-5**

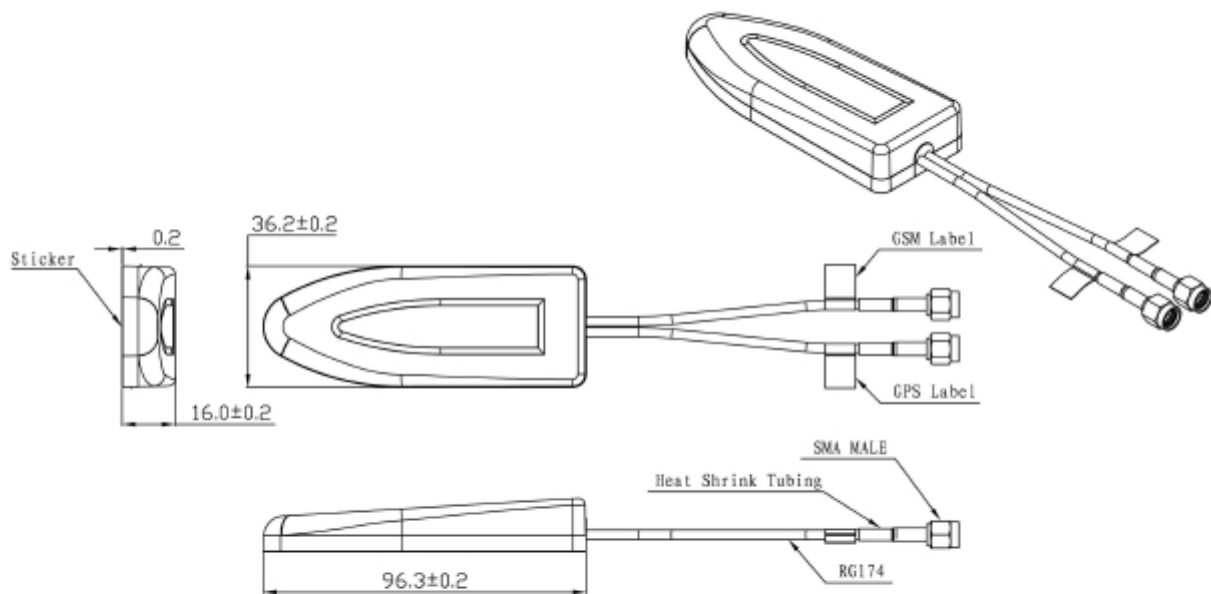

DIMENSIONS



Unit: mm

SPECIFICATIONS

Item	
------	--

GPS Antenna	Dielectric Antenna	Center Frequency	1595±3MHz
		Band Width	CF±5MHz
		Polarization	RHCP
		Gain	5dBic (Zenith)
		V.S.W.R	< 1.5
		Impedance	50Ω
	LNA	Gain	28±2dB
		Noise Figure	< 1.5
		Ex-band Attenuation	12dB@CF+50MHz/16dB@CF-50MHz
		V.S.W.R	< 2.0
		Supply Voltage	2.2~5V DC
	Current Consumption	5~15mA	
GSM Antenna		Frequency Range	824~960MHz/1710~2170MHz
		V.S.W.R	< 2.0
		Polarization	Linear
		Gain	2.0dBi
		Impedance	50Ω
Mechanical		Cable	RG174
		Connector	SMA/MCX/FAKRA or others
		Material	ABS
		Mounting Method	Magnetic/Stick
Environmental		Operating Temperature	-40℃~+85℃
		Relative Humidity	Up to 95%
		Ingress Protection	IP67 (exclude cable outlet)
		Vibration	10 to 55Hz with 1.5mm amplitude
		Environmentally	ROHS Compliant

Friendly

Radiation Pattern

GPS Antenna

V.TORCH

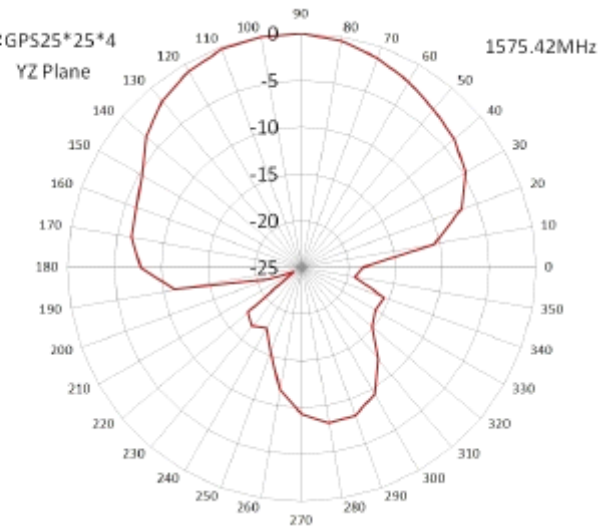
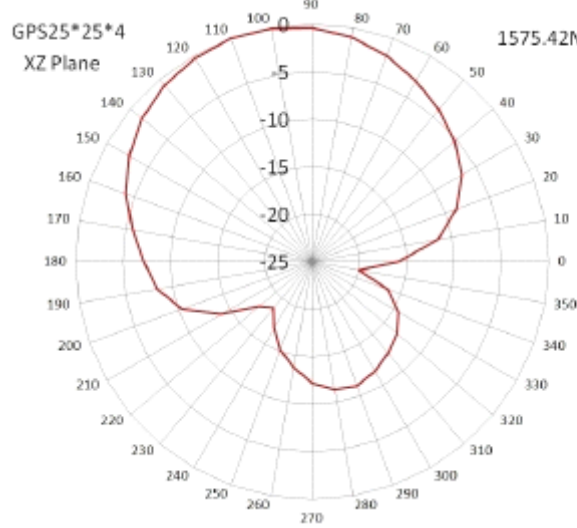
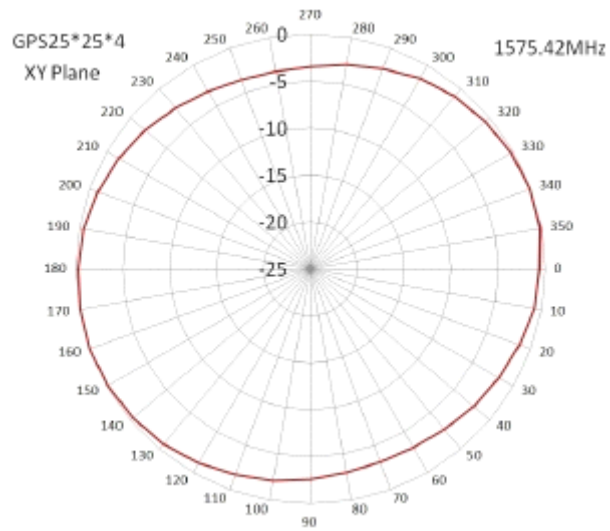

GSM Antenna

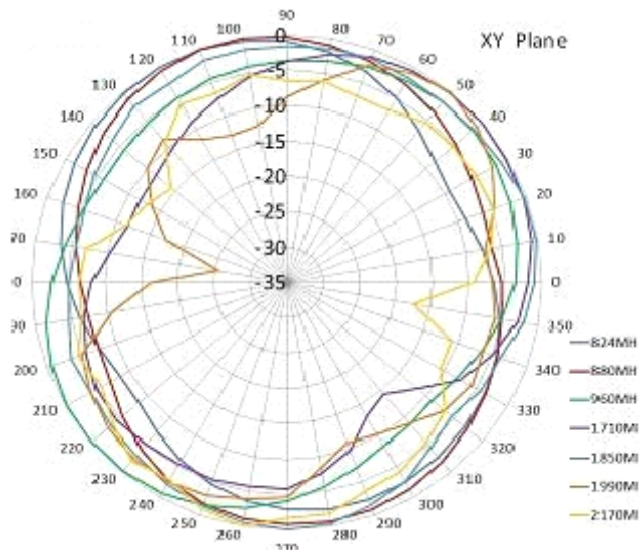

V.TORCH

